

SGT-0518

CHAVE DE IMPACTO 1/2" (40KGF.M)

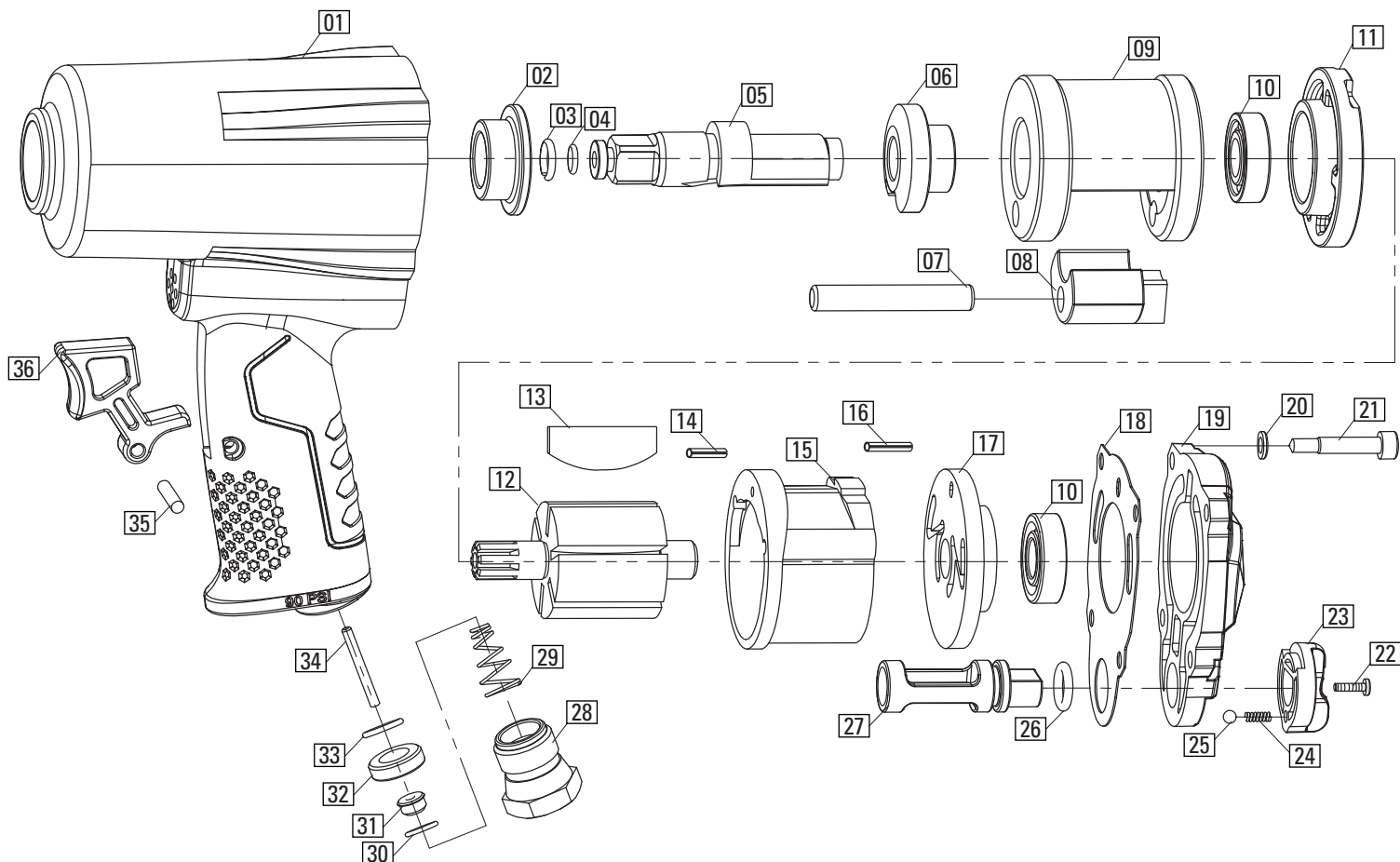

Nº	Código	Descrição	Qty./P.Máq.
01	0751051801	CARCACA - SGT-0518	1
02	0751051802	BUCHA DO BIGORNA - SGT-0518	1
03	0751051803	ANEL - SGT-0518	1
04	0751051804	O-RING - SGT-0518	1
05	0751051805	BIGORNA - SGT-0518	1
06	0751051806	CAME - SGT-0518	1
07	0751051807	PINO DO MARTELO - SGT-0518	1
08	0751051808	MARTELO - SGT-0518	1
09	0751051809	GAIOLA DO MARTELO - SGT-0518	1
10	0751051810	ROLAMENTO 6001 - SGT-0518	2
11	0751051811	TAMPA DIANTEIRA - SGT-0518	1
12	0751051812	ROTOR - SGT-0518	1
13	0751051813	PALHETA DO ROTOR - SGT-0518	6
14	0751051814	PINO 3X8 - SGT-0518	1
15	0751051815	CILINDRO - SGT-0518	1
16	0751051816	PINO 3X18 - SGT-0518	1
17	0751051817	TAMPA DO CILINDRO - SGT-0518	1
18	0751051818	JUNTA - SGT-0518	1

Nº	Código	Descrição	Qty./P.Máq.
19	0751051819	TAMPA TRASEIRA - SGT-0518	1
20	0751051820	ARREULA DE PRESSAO - SGT-0518	4
21	0751051821	PARAFUSO M5 X20 - SGT-0518	4
22	0751051822	PARAFUSO M4 X8 - SGT-0518	1
23	0751051823	BOTÃO DE REVERSÃO - SGT-0518	1
24	0751051824	MOLA - SGT-0518	1
25	0751051825	ESFERA DE AÇO - SGT-0518	1
26	0751051826	O-RING (PC-26) - SGT-0518	1
27	0751051827	VÁLVULA DIRECIONAL - SGT-0518	1
28	0751051828	ENTRADA DE AR - SGT-0518	1
29	0751051829	MOLA DA VALVULA - SGT-0518	1
30	0751051830	ANEL-O - SGT-0518	1
31	0751051831	VÁLVULA DE ADMISSÃO - SGT-0518	1
32	0751051832	ASSENTO DA VÁLVULA DE ADMISSÃO - SGT-0518	1
33	0751051833	O-RING (PC-33) - SGT-0518	1
34	0751051834	HASTE DA VALVULA - SGT-0518	1
35	0751051835	PINO - SGT-0518	1
36	0751051836	GATILHO - SGT-0518	1